

COMPACT POSI-FEED EMULSION/REDUCTION SYSTEM



PrimeCut™

COZZINI EMULSION/REDUCTION SYSTEMS



Touch screen display

COMPACT POSI-FEED EMULSION/REDUCTION SYSTEM

- Continuous or batch production.
- Variable speed feed pump provides complete control of product texture and temperature.
- Self-adjusting desired outlet temperature control.
- Cozzini MultiCut 7" diameter (180 mm) single or double plate/knife cutting system.
- Allen-Bradley touch screen, operator-friendly controls.
- Compact design and portable.
- USDA accepted and CE approved. Built in conformity with AMI sanitary equipment design principles.

COMPACT POSI-FEED EMULSION/REDUCTION SYSTEM

Cozzini introduces the new Compact Posi-Feed (CPF) series emulsion/reduction unit.

The CPF system assures the same consistent quality and throughput as Cozzini's well known VS and CS series emulsion/reduction systems.

The low-profile CPF features a 500-pound (230 kg) capacity hopper with a variable-speed feed pump. The variable-speed pump feeds the Cozzini MultiCut emulsion/reduction cutting head.

The CPF fits directly under the discharge of a mixer/blender or bowl chopper.

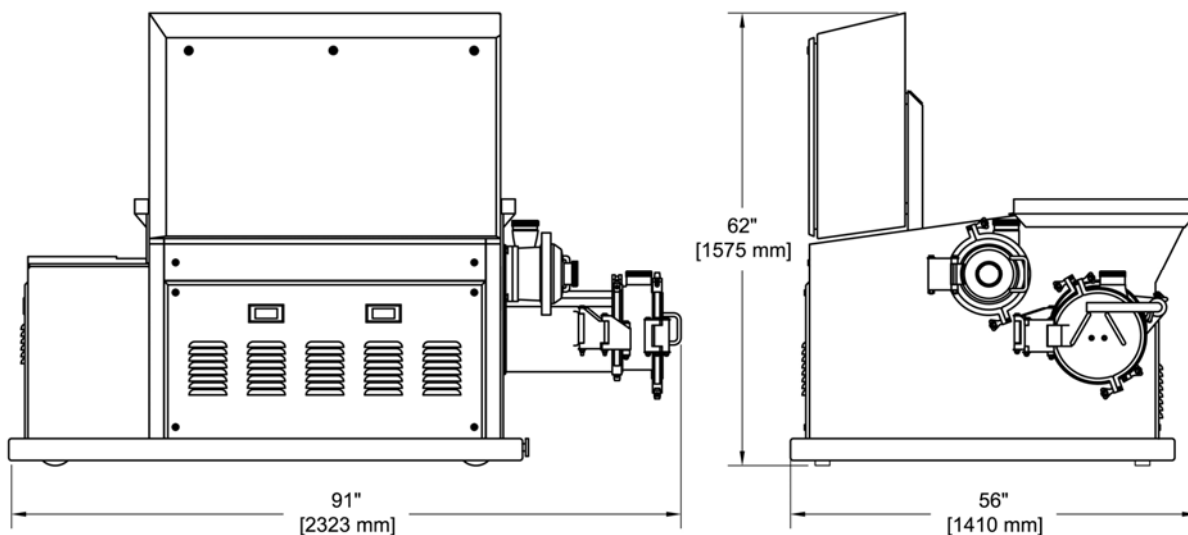

COMPACT POSI-FEED EMULSION/REDUCTION SYSTEM			
Voltage	hp	kW	Service Amps
380 V or 460 V	75/20 95 total	56/15 71 total	250 A

10/05 E



WORLD HEADQUARTERS Cozzini, Inc.
4300 West Bryn Mawr Avenue Chicago, IL 60646-5943 U.S.A

COZZINIGROUP
COMPLETE FOOD EQUIPMENT SOLUTIONS

WORLD REPRESENTATION • 773 478-9700 • www.cozzini.com • sales@cozzini.com