

## BACKCLAMP/GRIPPER STYLE SLICER



**PrimeSlice**™  
COZZINI/ANCO SLICING TECHNOLOGIES

### BACKCLAMP/GRIPPER STYLE SLICER

- Durable, low-maintenance slicer models for bacon, pepperoni, whole muscle meats, and numerous other products.
- Slice thickness ranges from .015" to .250" (0.4 mm to 6.4 mm).
- Variable speed blade turns up to 1500 rpm.
- Ram feed precisely indexes product to involute slicer blade.
- Shelf, gripper and finger hold-down module pneumatically powered for clean operation.
- Blade housing safety feature prevents opening until the blade has stopped turning.
- PanelView controls for user-friendly interface.
- USDA accepted and CE approved. Built in conformity with AMI sanitary equipment design principles.

# BACKCLAMP/GRIPPER STYLE SLICER

Cozzini/Ancò Slicing Technologies introduces its line of multi-purpose slicers for precision, high speed slicing of bacon, pepperoni, whole muscle meats, formed meat logs and more, with slice thicknesses ranging from .015" to .250" (0.4 mm to 6.4 mm). The involute slicer blade is driven by a central shaft, turned by a motor and timing belt. A second motor drives the ram feed along a linear horizontal track.

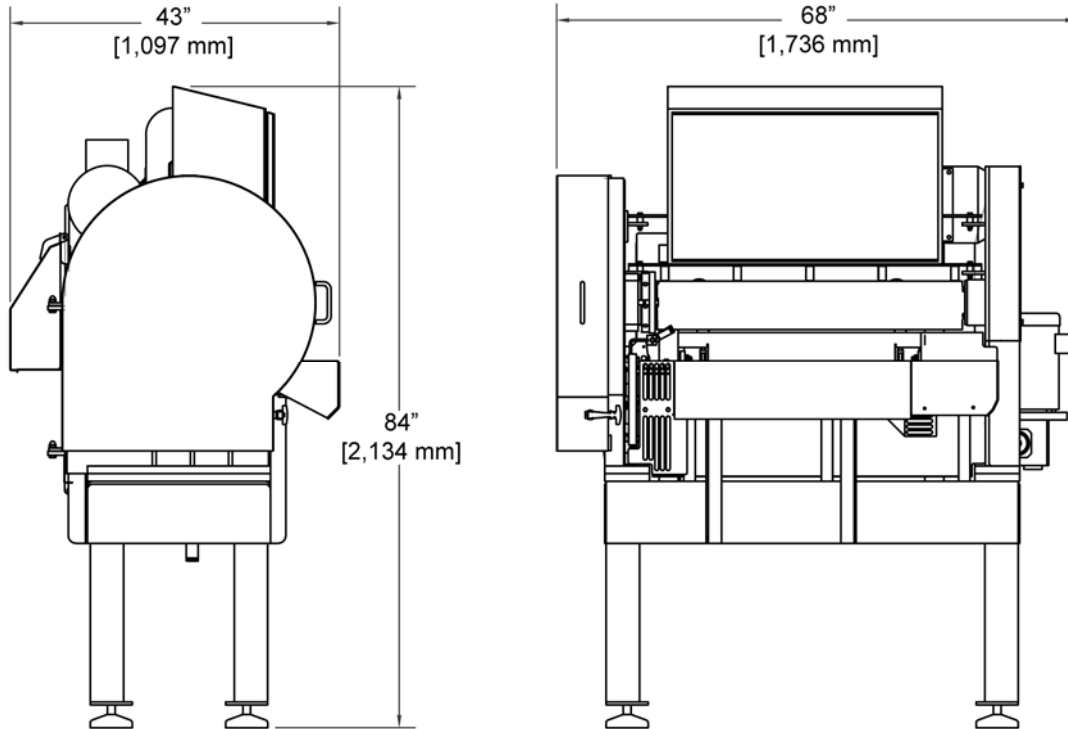

Model	Orifice Dimension	Max Product Length	Motors		Service Amps	Operating Pneumatic Pressure
			Ram Feed	Slicer Blade		
CA827	5" x 10" wide [127 x 254 mm]	30" [762 mm]	1.5 hp [1.1 kW]	5 hp [4 kW]	30 A 220 VAC/3 PH	75 psi [5 bar]
				Optional 7.5 hp [5.6 kW]	Optional 15 A 460 VAC/3 PH	

10/09 E

WORLD HEADQUARTERS Cozzini, Inc.  
4300 West Bryn Mawr Avenue Chicago, IL 60646-5943 U.S.A

**COZZINIGROUP**  
COMPLETE FOOD EQUIPMENT SOLUTIONS

WORLD REPRESENTATION • 773 478-9700 • www.cozzini.com • sales@cozzini.com